

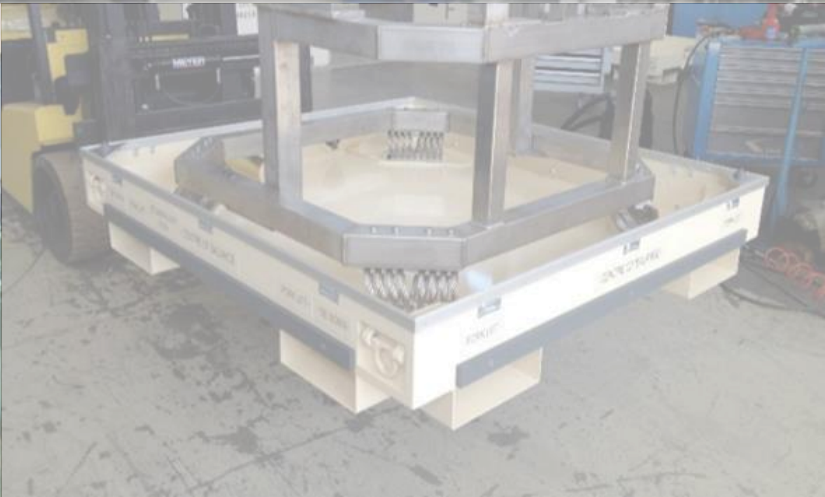

TESTING SOLUTIONS

The logo for BVA TESTING SOLUTIONS is centered in the image. It features the letters 'BVA' in a white, stylized, sans-serif font against a solid blue square background. Below the blue square is a thin white horizontal line, and below that is the text 'TESTING SOLUTIONS' in a black, sans-serif font.

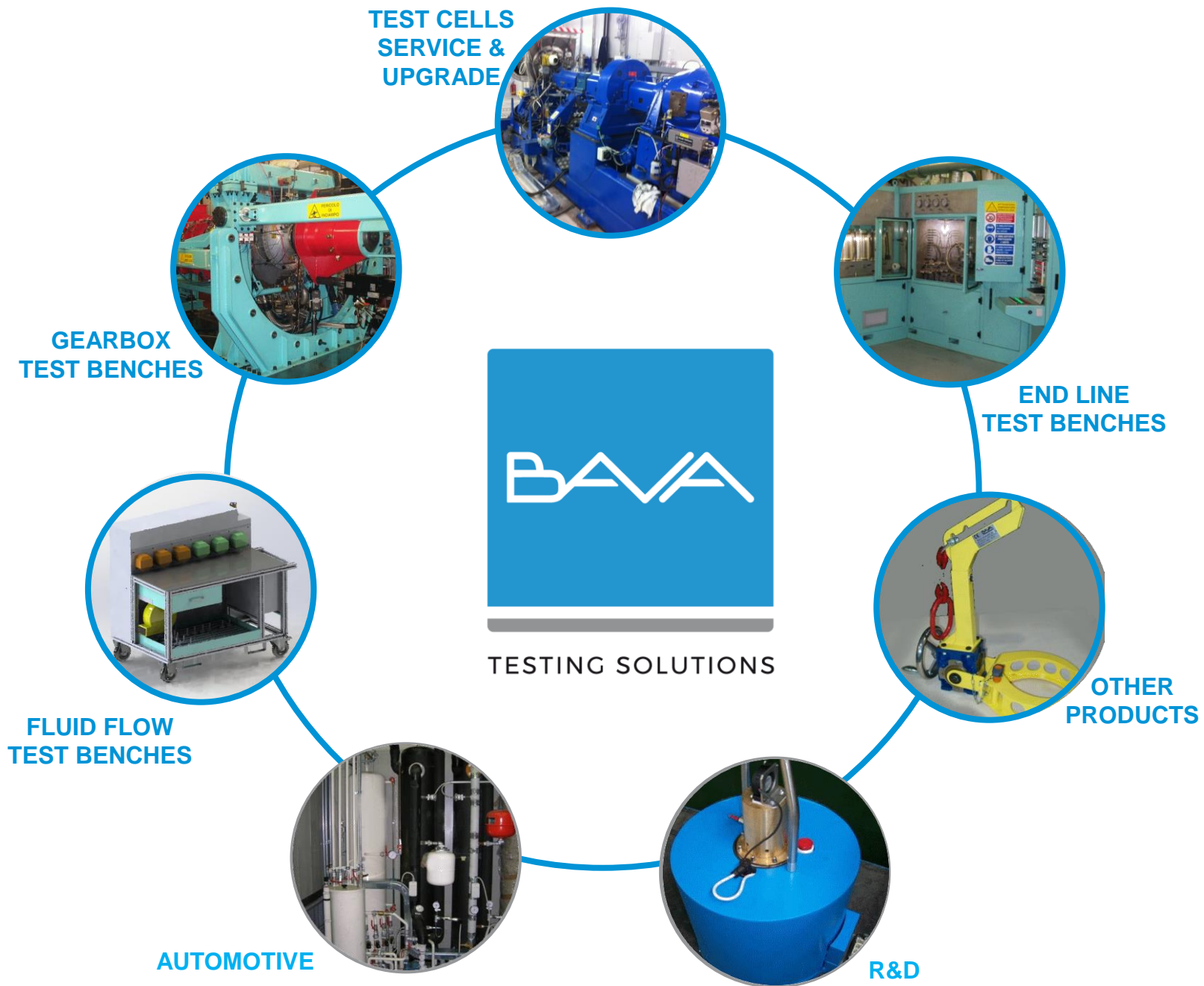



RICERCA & SVILUPPO

La collaborazione con Università ed Enti di Ricerca ci ha negli anni condotti a partecipare a svariati programmi e progetti nazionali ed europei:

- CLEANSKY (Sage2/Sage4)
- GREAT 2020
- Neck Wall
- HELIOS HP





TESTING SOLUTIONS

BANCO PROVA SCAMBIATORI ARIA-ARIA
B_21307



TESTING SOLUTIONS

BANCO PROVA SCAMBIATORI ARIA-ARIA

B_20214



TESTING SOLUTIONS

BANCO PROVA FLUSSI TERMICI

B_21654



TESTING SOLUTIONS

BANCO PROVA FLUSSI TERMICI
B_20992

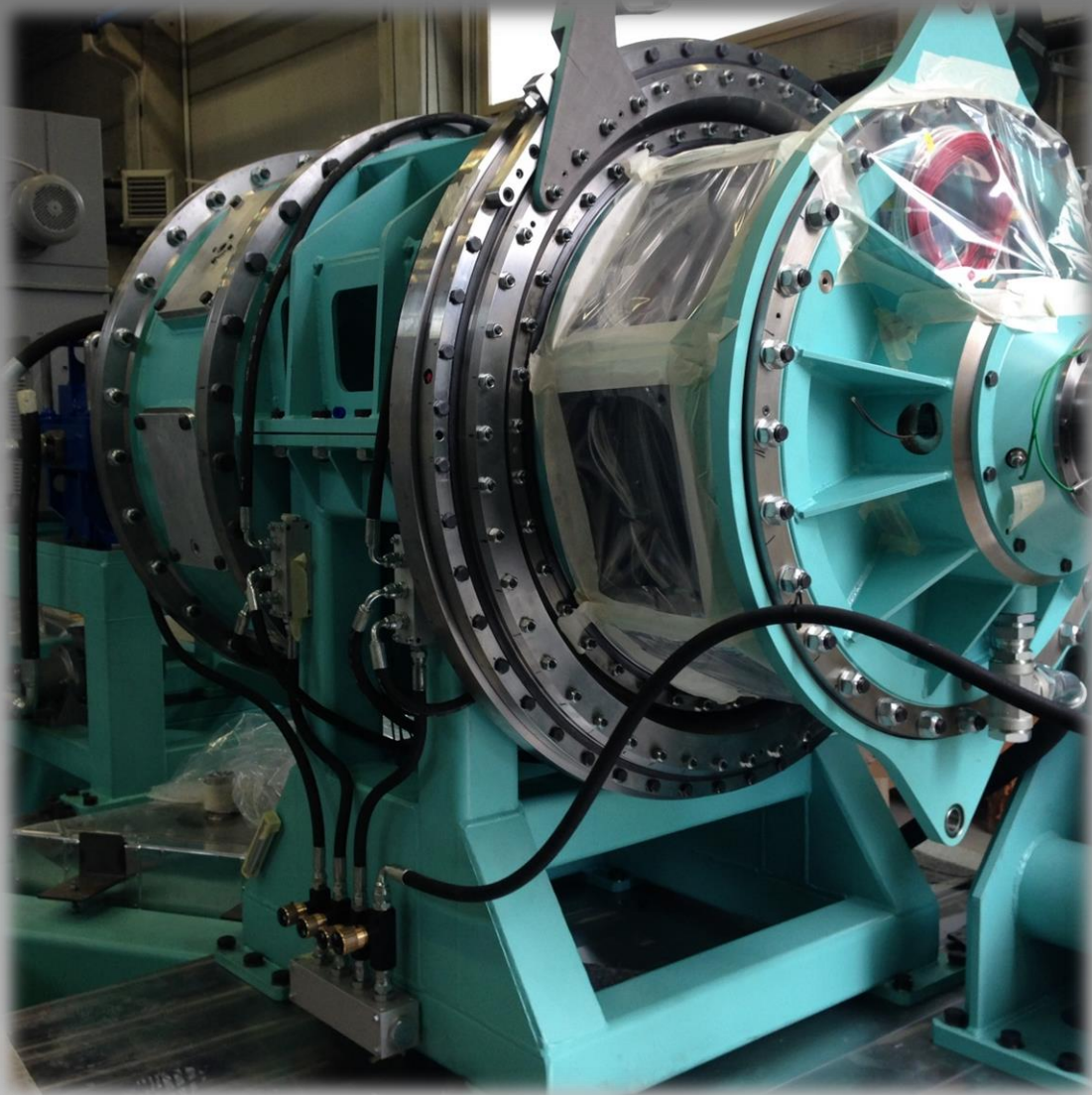

BVA

TESTING SOLUTIONS

BANCO PROVA SCATOLA INGRANAGGI

B_22117

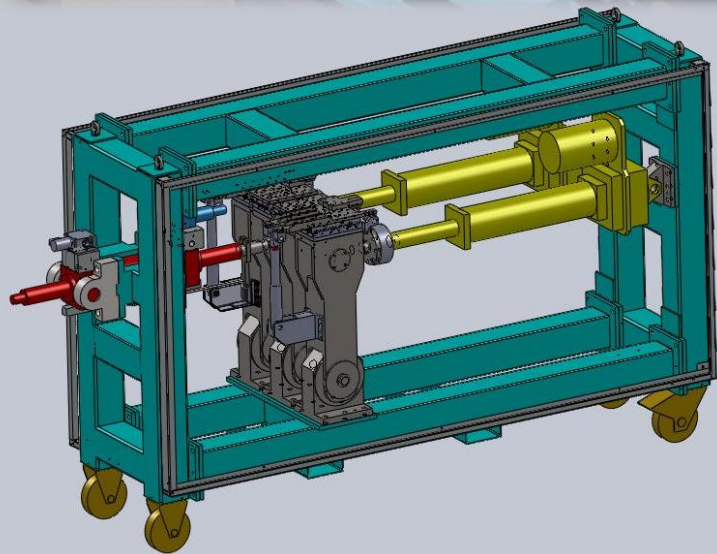

BANCO PROVA ATTUATORI ELETTRICI
B_20828



TESTING SOLUTIONS

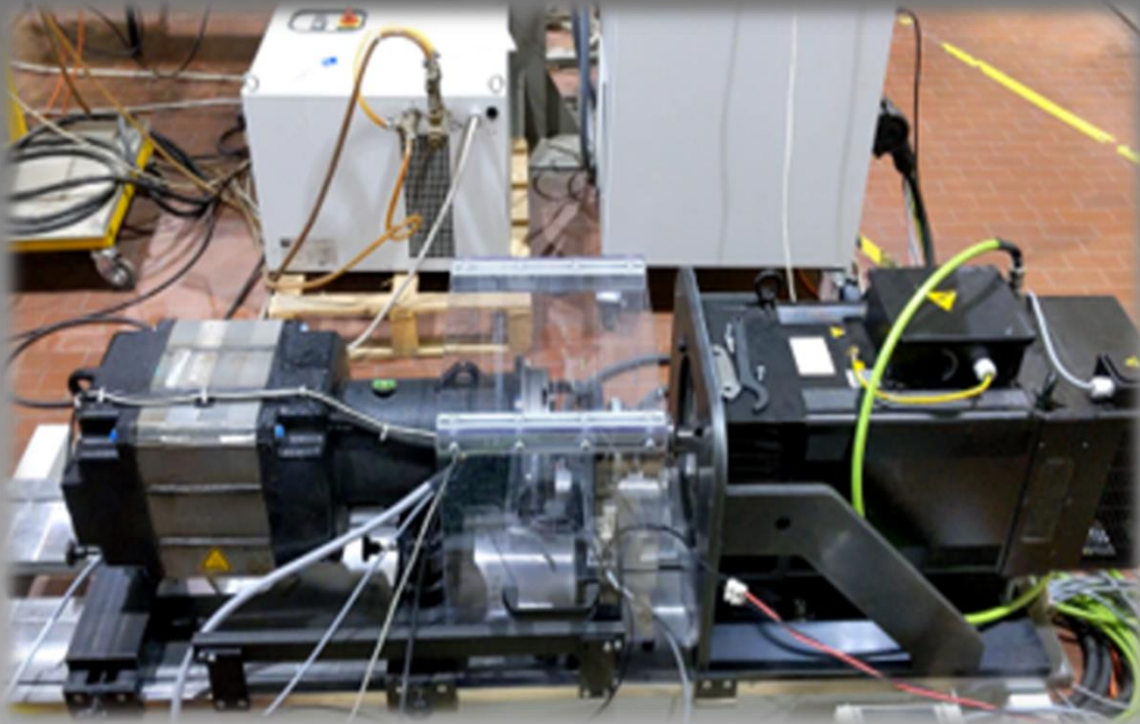

TESTING SOLUTIONS

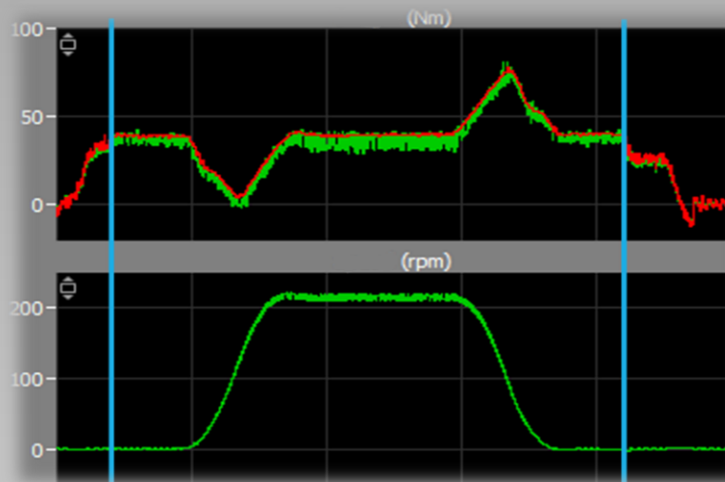

BANCO PROVA MOTORI ELETTRICI
B_22885



TESTING SOLUTIONS

BANCO PROVA CARICA OTTIMALE GAS REFRIGERANTI
B_22851



GENERATORE DI VAPORE METABOLICO (EEC78/317)

B_22186



TESTING SOLUTIONS



BAVA S.r.l.

Via Riccardo Lombardi, 9 – 10028 Trofarello (TO) – Italy
phone +39 011 3496606 - fax. +39 011 3496606

email: info@bavasrl.it

